

## EVENT FENCE

Event Fence portable barrier is a system of interlocking free standing fence panels. Strength, durability and flexibility are all features of Event Fence! Simply link Event Fence panels together to create continuous barricading for festivals, parades, sporting events or work sites.

Optional forklift stillage make storage and transporting of Event fence panels simple and efficient.

### Value features:

- » Fully welded steel construction.
- » Galvanised finish.
- » Panels nest together when not in use to reduce storage space.
- » Feet are removable if desired for freight or storage.
- » Vertical bars eliminate climbing points.
- » Panels are able to pivot at joints.
- » Low profile feet reduce tripping hazards.

### Specifications:

<b>Description:</b>	Modular and portable temporary barrier system.
<b>Material:</b>	Steel construction, fully welded.
<b>Finish:</b>	Hot dip galvanised.
<b>Length:</b>	2200mm.
<b>Width:</b>	490mm.
<b>Height:</b>	1100mm.
<b>Weight:</b>	16kgs.
<b>Installation:</b>	Free standing panels, link together. No tools required.

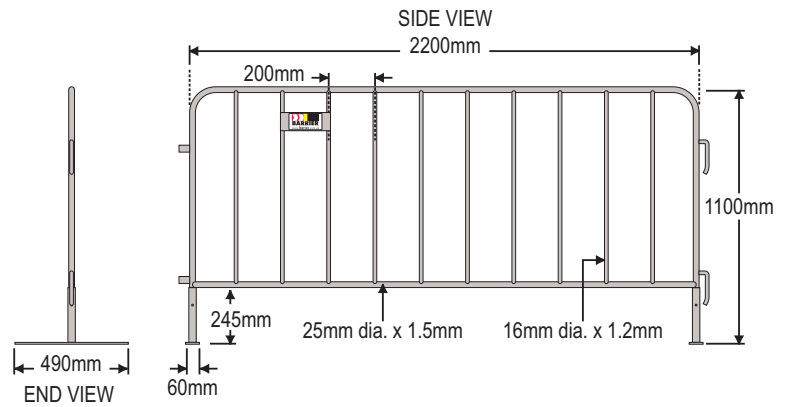

### HANDY TIP

Buyers considering purchasing event fence should also consider our EFS stackable forklift stillages. These stillages make the storage and handling of event fence panels much more space efficient and easier to handle. EFS (Optional) stackable forklift stillage. Designed to hold 30 x EF25/200. For more information see Section 7.10.2.

PART No.	DESCRIPTION
EF25/200	Standard Duty Event Fence
EFS	Event Fence Forklift stillage – stackable

## EVENT FENCE STILLAGES

Optional fork lift stillages make the storage, handling and transportation of large numbers of Event Fence panels simple and efficient.

These robust hot dip galvanised steel stillages hold either 30 pieces of the EF25/200 standard duty event fence panels or 14 Crowd-Q Panels.

### Value features:

- » Robust construction with galvanised finish.
- » Designed for use with forklifts.
- » Stackable to 4 units high.
- » Each unit holds up to 30 Event Fence panels.
- » Panels can be hand loaded by one person.

PART No.	DESCRIPTION
EFS	Event Fence stackable forklift stillage



EFS – Stillages make storage and handling of panels simple and space efficient.

# LEGEND



## AUSTRALIAN CONTENT

This product has been designed, developed and is either completely or substantially manufactured in Australia. (The minimum Australian content is between 50 and 100%).



## NEW AND UNIQUE

This is a new and unique product. It has either been designed, developed and manufactured by the Barrier Group Pty. Ltd. or it is being seen here for the first time.



## 100% RECYCLABLE

This product is manufactured from virgin grade raw materials and is 100% recyclable using existing, readily available recycling technology and services.



## RECYCLED MATERIALS

This product has been manufactured from either a combination of recycled materials and virgin grade materials or entirely from recycled materials.



## HOT DIP GALVANISED

This product has been hot dip galvanised prior to any surface coatings being applied. Hot dip galvanised offers vastly improved corrosion protection and extended life in harsh environments.



## FIXINGS INCLUDED

This product comes complete with all the necessary fixings to complete the standard installation. When comparing competitors prices against our own, always ensure they have included the fixings with the product (excludes gravel spikes).



## 5 YEAR WARRANTY

This product carries a 5 year limited warranty against structural failure due to faulty materials or workmanship in our manufactured products, OR structural failure and major fading due to U.V. degradation in our injection moulded products.

(For full conditions visit [www.barriergroup.com.au](http://www.barriergroup.com.au)).

## WARNING

© Barrier Group Pty. Ltd. takes the protection of its intellectual property (IP) seriously and will not hesitate to pursue legal action against any individual, group or organization attempting to steal, copy or duplicate any of its proprietary designs OR anyone who imports, sells or distributes illegal copies or duplicates of its proprietary designs.

IT'S AGAINST THE LAW – AVOID THE PAIN!