

'MENNI' FENCE

'Menni' fence uses the components of the 'Menni' system with FRP (Fibreglass Re-inforced Plastic) components to create a truly modular pedestrian separation and management system.

Both the 'Menni' and FRP components are impact resistant, highly durable, flexible and have solid colour moulded in. They won't fade, rot, or rust and are UV stabilised.

This product requires on site assembly and installation.

'Menni' fence allows easy fabrication in the field without the need for welding. It is ideal for hazardous environments due to its low electrical and thermal conductivity and its non-corrosive components. Moulded sockets in the 'Menni' components allow the 50mm diameter FRP posts to be inserted. The combination of FRP fittings and rails in standard 5 metre length allows complete flexibility of design. (For more information on the 'Menni' components see Section 9).

Value Features:

- » Strong, flexible, lightweight and highly visible.
- » Ease of on-site fabrication without welding.
- » 'Menni' designed to receive 50mm FRP posts.
- » Solid colour won't rot, rust, fade or peel.
- » U.V. stabilised
- » Non-conductive. Corrosion and chemical resistant.
- » The 'Menni' system meets AS1657 for toe boards.

Specifications/Components:

Menni: See Section 9.1.2.

FRP: See Section 2.2.



PART No.	DESCRIPTION
BME-Y	'Menni' end module – Yellow
BMB-Y	'Menni' body module – Yellow
BMT-Y	'Menni' T-intersection module – Yellow
BMC-Y	'Menni' 90 degree corner module – Yellow
BMR	Optional top reflector
FRP50Y	FRP tube 50 O.D. x 40 I.D. x 5mm wall
FRPSJ38	Slip Joiner for rails
FRPT	2 piece tee with fixings
FRPC	2 piece cross with fixings
FRPE	2 piece elbow with fixings
FRP3C	1 piece 3way connector
FRP4C	1 piece 4way connector
FRPCAP	Plastic cap for tube
FRPSB	Double sided 50mm sign post bracket

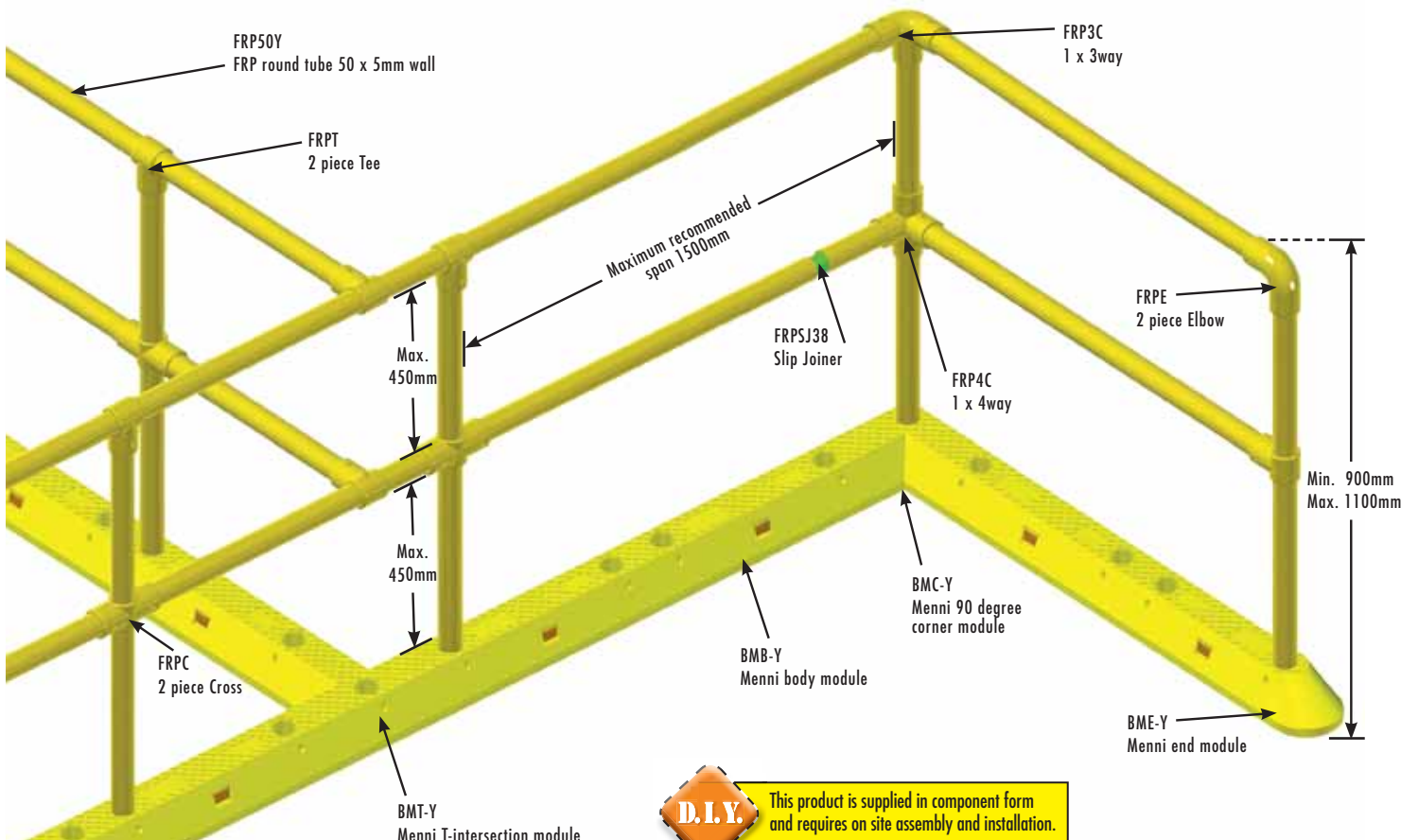
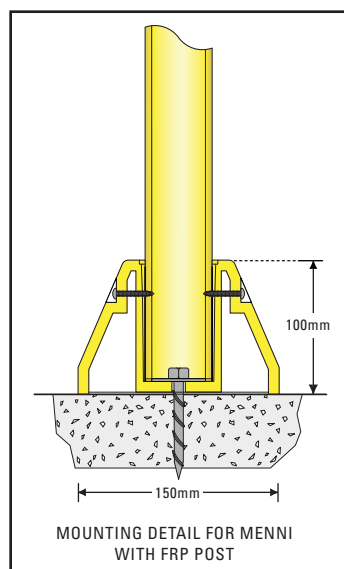

D.I.Y. This product is supplied in component form and requires on site assembly and installation.

'MENNI' FENCE

Installation Procedure:

- Using a chalk line, set out and position 'Menni' modules and connect together with connector plugs supplied. With a 10mm drill bit and impact drill, pilot drill the mounting holes for each module. (PHOTO'S 1 & 2).
- Move the modules to one side and drill piloted holes with a 14mm drill bit 100mm deep. (Note: If using concrete screw bolts instead of plastic plugs and coach screws drill size is only 10mm). Clean dust from holes, insert plastic Hilti plugs and hammer flush with floor. Reposition modules and bolt down using washers and coach screws supplied. (PHOTO'S 3 & 4).
- With a mallet and the piece of wood to protect the post fully drive the posts into the sockets in the 'Menni' modules. (Note: Posts must be continuous and spacings should not exceed 1500mm).
- Measure and cut handrails. (Note: Handrails must be continuous. For handrails longer than 5 metres use slip joiners and screw fix them from below. Using clamps to hold fittings in place drill through fitting and post wall from both sides with a 6mm drill. Enlarge hole on one side to 9mm. Fit screws supplied and lightly tighten. (PHOTO 5).
- Measure and cut knee rails to suit post spacings. Clamp and drill as per step 4. (PHOTO 6).
- Go over completed installation and tighten all connections. (PHOTO 7).

INSTALLATION NOTES:

- Always use a face mask when drilling or cutting.
- To achieve long, straight lines use a string or chalk line.
- On completion check all fixings are tight.



1.



2.



3.



4.



5.



6.



WHAT YOU WILL NEED

- Tape measure and string line.
- Impact drill and masonry bits.
- Electric drill and bits.
- Socket wrench or impact driver.
- Power saw or hacksaw.
- 4mm Allen key.
- Clamps.
- Mallet and piece of timber.



7.



The two types of fixings available.