

Works on Australian 3G & 4G Mobile Networks



Part No. KRG-3000v3

- Metal keypad.
- Robust Anti-vandal unit
- Stainless-steel door station.
- Easy installation – four wires only.
- Anti-Vandal Speaker and Microphone.
- Water resistance unit for external use.
- Operation voltage: 12V – 24V Ac / DC
- Front panel illuminated by Blue light at night.
- Wireless GSM Intercom for up to 333 houses.
- Wireless Programming by phone from anywhere.
- Full Access Control Keypad for up to 1000 users.
- Guiding Speaking System enabling easy programming.
- Two relay outputs to control driveway gate and Pad gate.
- GSM Access Control for 1000 users to open the gate with their mobile phone with no cost of a call.

Application

- Intercom for building of up to 333 apartments
- Access control entry to car park with wireless intercom.
- Wireless Intercom for resorts and hotels with programmable access control keypad.
- Keyless entry access control to factories.
- Government buildings.
- Shopping centers.

Technical

Dimension in mm	H 195 x W100 x D 50
Operation voltage:	12V Ac or Dc / or 24V DC only
Power Supply current rating:	min. 1,2A @12V
Power Supply ripple:	max. 120mV
Input current in idle mode:	25mA @ 12V
Input average current	100mA @ 12V

GSM frequencies: The unit supports quad band GSM frequencies

- GSM-850
- E-GSM-900
- DCS-1800
- PCS-1900

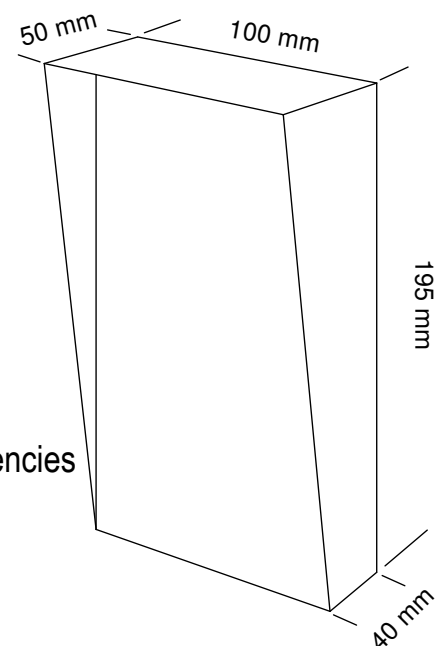

General Information

The KRG-3000v3 is a Multi Channel GSM wireless Intercom system that can save you enormous hours of labor in installation and kilometers of wiring which is required for installing intercoms and access control system to any building of apartments or for any complex of up to 333 houses. The installation of the unit takes a few minutes and requires connection to power supply and connection of two wires for command to open the gate. The unit requires a SIM card to be used to make calls to the houses.

Intercom

This Hi-Tech **talking system**, will ask the visitors to make a call to one out of the 333 units in a complex of apartments, by pressing the house number followed the hash (#) key. The system then will call the first phone number which was stored in memory of the system for that unit apartment (for example the land line of the unit). The owner of the unit can answer the call and talk with the visitor and open the pedestrian gate or the drive way gate for the visitor by pressing the # key or the * on his phone. The system will automatically hang up if the call was not answered by the owner and try the second and third additional phone numbers which were programmed in the system for this apartment unit. These numbers can be the mobile phone numbers of the owners. This smart system will announce: "Your call was not answered – please try later" if the owner of the unit did not answer the phone numbers in the system.

Access Control

The system enables up to 999 users of the building to open the gate with their mobile phone from any distance with no limit of range and with no cost of a call to them. The system also enables the users to open the gate with a four-digit pin code with the metal keypad of the door station.

Service Free Maintenance

All the programming of the system can be done on site or wirelessly by the Master phone number.

Notes:

KELRYAN

1300 535792

Part No. KRG-3000v3

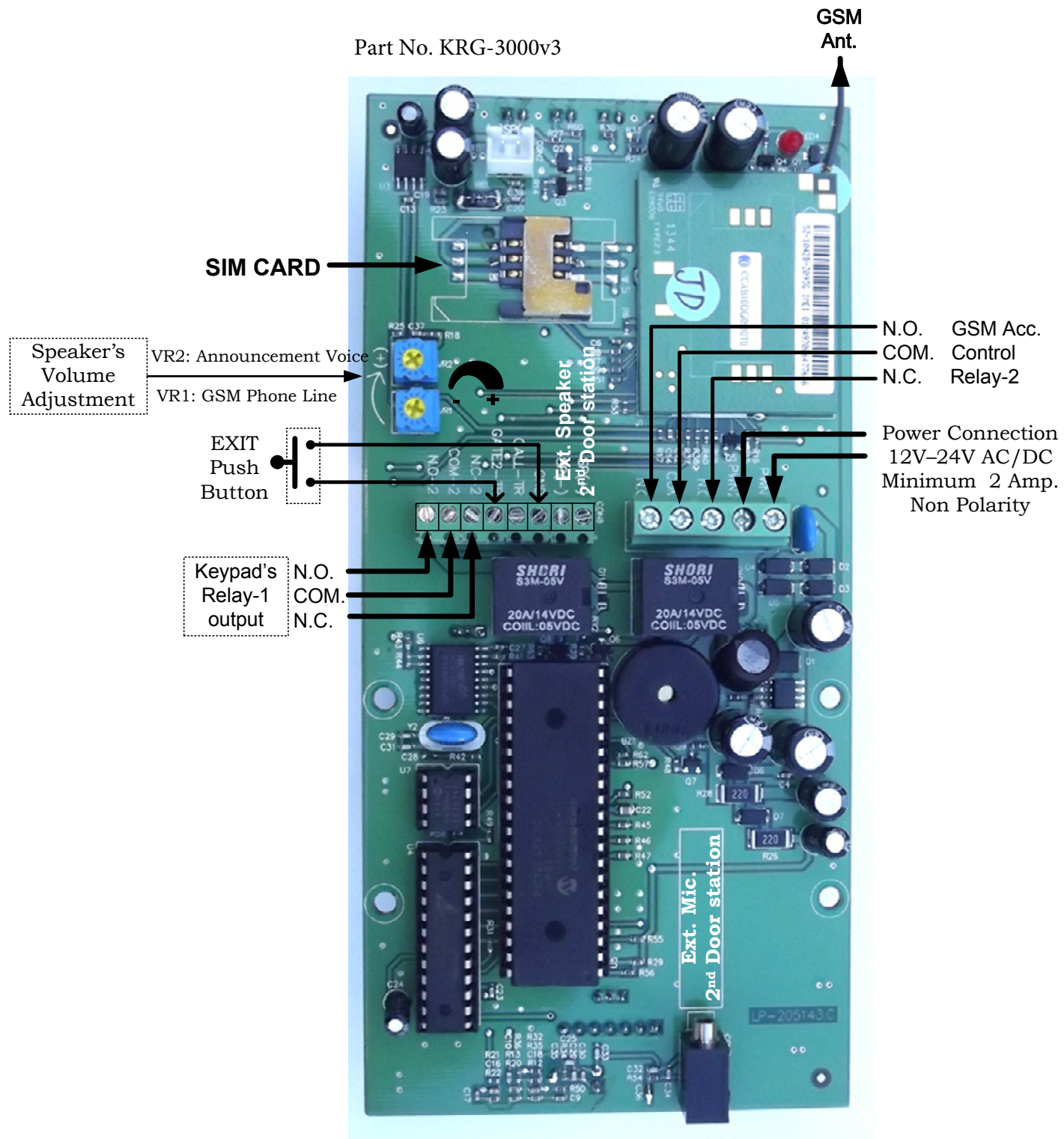

KELRYAN

Parking Automatic Gates High Security Automation & Traffic Safety

Unit 12 / 7 Investigator Drive Unanderra NSW 2526

Ph: 1300 535792

1300 KELRYAN